

ISI - UFT

STAND-BY SINGLE PHASE AC SINE WAVE UNINTERRUPTIBLE CENTRAL SYSTEM

The Inverter Systems, Inc. ISI-UFT provides a high efficiency single phase "stand-by" central AC emergency power system ideally suited for H.I.D., fluorescent and incandescent emergency lighting applications or other auxiliary loads that require a "fast transfer, no-break" voltage regulated and line conditioned power supply.

The ISI-UFT demonstrates exceptional 97% operating efficiency by means of the fast "no-break" transfer circuit, providing considerable running cost savings over typical double conversion UPS systems. Available in a wide range of capacities and voltages, the ISI-UFT is designed to provide up to 90 minutes of standby emergency power in accordance with the requirements of U.L. 924.

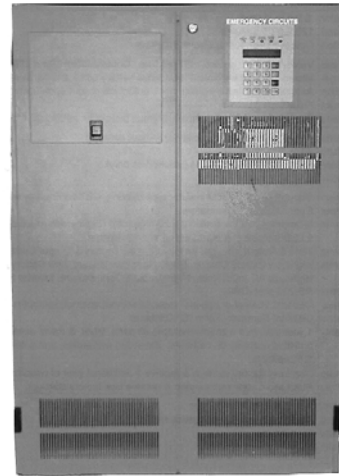

OPERATION

The inverter is normally off and the commercial AC power continuously supplies the critical load. The input converter (bi-directional transformer) derives power from the commercial AC power source and supplies to the inverter while simultaneously providing floating charge to the batteries.

Upon failure of the commercial AC power the inverter instantaneously, with a maximum of a 2-millisecond break, switches its power supply from the input converter to the battery system. There shall be no loss of power to the critical load upon failure or restoration of the utility source.

An automatic low voltage cutoff circuit disengages the inverter system at the useful end of the battery capacity preventing deep discharge battery damage. Upon restoration of the utility supply the system automatically returns to the normal "standby" mode and restores the battery to full charge.

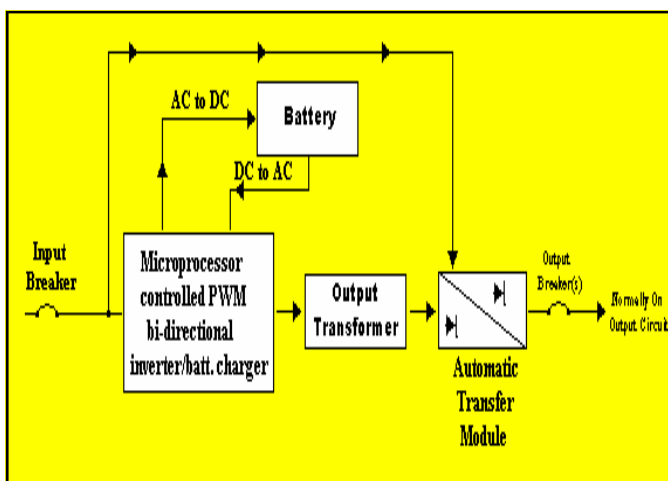

STANDARD FEATURES:

- Available in standard capacities from 1500 VA to 16.7 kVA
- Modular design provides electronic assemblies mounted on removable modules for ease of maintenance
- 97% high-efficiency stand-by operation
- Industry proven continuously on PWM inverter utilizes switching transistor failure whilst still maintaining full rated load output
- Short-circuit protected with critical point fuses and breakers
- Digital metering indicates: input voltage, output voltage, output frequency, output current, battery voltage, battery current, VA output, inverter watts, ambient temperature, system day, inverter minutes
- System test switch
- Available with many alarm function, monitoring and diagnostic options -refer Option Selection chart
- Maintenance free sealed lead calcium batteries standard, wet nickel cadmium batteries optional
- Heavy gauge steel cabinets with filtered air louvers, key locks and removable hinged front opening doors for ease of access and maintenance
- Engineered for standard 90 minute emergency operation, (extended run times available)
- Suitable for extreme temperature from 0 to 40 C (continuous operation at high or low ambient temperatures may affect battery capacity and life; see battery warranty sheet for details)
- Input lighting protection meets IEEE/ANSI C62.45-45 (CAT A & B)
- Input current harmonic distortion 10% or less at full load
- Input circuit breaker included for complete protection
- Load power factor .5 lag to .5 leading
- Output distortion 3% THD linear load
- U.L. 924 listed

All specifications subject to change without notice.

ISI-UFT Model Capacity VA	Efficiency @ full load	Heat Loss BTU's	Inverter Cabinet Dimensions (inches)			Weight (lbs.)	Battery Cabinet Dimensions (inches)			# Batt. Cabinets Required	Weight of add'l Batt. & Cabinet (lbs.)	Total system shipping weight (lbs.)
			W (A)	H (B)	D (C)		W (D)	H (E)	D (F)			
ISI-UFT-1500	97%	75	30	46	22	215				--	81	296
ISI-UFT-2250	97%	100	30	46	22	230				--	214	444
ISI-UFT-3000	97%	160	30	46	22	235				--	357	592
ISI-UFT-3750	97%	200	30	46	22	240				--	500	740
ISI-UFT-4800	97%	245	30	46	22	280				--	608	888
ISI-UFT-6000	97%	300	30	46	22	300	30	46	22	1	960	1410
ISI-UFT-8000	97%	400	30	46	22	335	30	46	22	2	1445	1815
ISI-UFT-10,000	97%	500	30	46	22	440	30	46	22	2	1636	2216
ISI-UFT-12,500	97%	660	30	46	22	460	30	46	22	2	2060	2680
ISI-UFT-16,700	97%	840	30	46	22	500	30	46	22	3	2910	3460

SPECIFICATIONS:

- The emergency lighting inverter system shall be a stand-by no-break system suitable for sustaining and operating H.I.D., fluorescent and incandescent lamps in the event of a power outage for a minimum 90 minutes duration at the rated load and be listed and labeled to U.L. 924.
- The entire system shall be of a modular construction with removable electronic modules for ease of installation and maintenance. Cabinets shall be constructed of code gauge steel with removable key locked hinged doors finished in an acid resistant enamel with a modified vinyl undercoat.
- The inverter shall be a standby UPS. PWM inverter type utilizing IGBT technology with 2mS transfer time.
- The AC input voltage shall be (120 or 277V single phase two wire plus ground).
- The output voltage shall be provided as a) 120 or 277V single phase, two wire **normally on**, or b) 120 or 277V single phase, two wire or mixed 120V @(specify) VA, 277V @(specify) VA **normally off**. The output frequency shall be 60HZ ± 0.05HZ for all loads.
- The system shall reliably handle from .5 leading to .5 lagging power factor. The output voltage regulation shall be ±3% or better from 0% to 100% of rated load. The system's output shall be capable of 125% overload for 5 minutes. Harmonic distortion <10% total or 3% any single harmonic.
- The battery charger, in the standard configuration shall convert AC voltage to DC voltage. With commercial power present, the inverter power transformer is powered and the IGBT modules are microprocessor controlled to recharge the batteries. The temperature compensated battery charger circuit supplies constant voltage and constant current to the batteries. Once the batteries have received full recharge, a constant trickle charge maintains batteries at maximum level. Recharge time is 24 hours maximum at nominal AC input voltage. The AC ripple current of the DC output meets the battery manufacturer specification, ensuring maximum life.
- The system's batteries shall be of the (sealed maintenance free lead acid) or (wet vented nickel cadmium) type.
- Options: Refer to Option Selection Chart for descriptions and nomenclature. Popular options are: Start-up Service, Output Circuit Breakers, Maintenance Bypass Switch, Output Trip Alarms
- The system shall be an Inverter Systems model No. _____ as manufactured for and warranted by Inverter Systems, Inc. (for copy of detailed specification format - consult factory)

ORDERING GUIDE:

When ordering an ISI-UFT from Inverter Systems, Inc., use:

ISI-UFT - 7500 - 277 - 277 - C(4) - SB - OPTIONS
 1 2 3 4 5 6 7

- Model Series** ISI-UFT
- Volt Amp (VA) Rating** 1500 to 16700
Select required capacity in volt Amps from model tables above
- Input Voltage**
120V 2 wire plus ground 120
277V 2 wire plus ground 277
Other voltages (specify) ()
- Output Voltage**
120V 2 wire plus ground 120
277V 2 wire plus ground 277
Other voltages (specify) ()
- Output Circuit Breakers**
Specify number of output circuit Breakers (maximum 10 per system) C ()
- Battery Type**
Maintenance free sealed lead acid SB
Wet nickel cadmium NC
- Options**
Select requirements from Options Guide, Popular options are:
Start-up Service SUS
Output Trip Alarm OTA
Summary Dry Contacts (Form "C") DCS
Maintenance Bypass Switch MBYP

WARRANTY:

Electronics Assembly

Inverter Systems, Inc. warrants the ISI-UFT electronics assembly (except batteries) against defects in material and workmanship for a period of one year from date of shipment. Inverter Systems, Inc. will either repair or replace any properly installed ISI-UFT system which fails under normal operating conditions provided that it is returned to the factory, transportation prepaid, and our inspection determines it to be defective under the terms of this warranty.

The warranty covers only equipment other than batteries manufactured by Inverter Systems, Inc. and does not extend to transportation, installation or replacement charges, nor does it apply to any other equipment of another manufacturer used in conjunction with ISI equipment. No other warranty expressed or implied exists beyond that included in this statement.

Battery Warranty

Sealed lead calcium batteries carry a 1 year full, 9 year pro-rated limited warranty. Wet nickel cadmium batteries carry a 1 year full, 10 year pro-rated limited warranty.

Important note: Battery warranty is limited to certain environmental, operational and installation limitations (refer to detailed Battery Warranty Terms and Conditions).

