Introduction	1
Registering Your UPS	1
Technical Support	1
FCC Compliance	1
Safety Compliance	1
Safety	1
Intended Use	1
Safety Notices	2
Emergency	3
Leakage Currents	3
Radio Interference	3
Batteries	3
Repackaging	3
Notes Regarding the EU Declaration of Conformity	3
About the Operating Instructions	4
Device Overview	4
Symbols	4
Documentation Structure	4
Preparation for Use	4
Delivery and Storage	4
Installation	7
Electrical Preparations	7
Installation Data	8
Cable Sizes and Current	9
Neutral Connection	10
External Protection and Isolating Devices	10
Installation of Differential Protection Devices	10
Terminal Blocks for UPS	11
Connecting Mains	12
Connecting Load Cables	12
External Battery Connection	12
Auxiliary Backfeed Protection	13
Operation	13
Reset	13
Operating the Device	13
UPS Start-Up Procedure	14
UPS Shutdown Procedure	15
Functional Test	15
Indication and Operating Elements Linear Plus Rack-mount	15
Indication and Operating Elements	16
Remote Power Off (RPO)	18
Emergency Power Off (ESD hardwired)	19
Paralleling UPS Devices	19
Designing a Parallel System	19
Parallel System, Installation and Operating	19
Maintenance	21
Battery Replacement	21
Storage	22
Cleaning	22
Interfaces	22
Serial Interface COM 3	22
Optional Isolated Contacts Card	24
Troubleshooting	25

Introduction

Thank you for selecting this uninterruptible power supply (UPS). Chloride's Linear Plus Rack-mount Series UPS offers the most reliable protection from the harmful effects of electrical line disturbances for your computing and communications equipment. Chloride's ISO 9001 certification represents our commitment to building world-class products. We take pride in every unit that leaves our facility.

Registering Your UPS

To ensure that your Linear Plus Rack-Mount Series UPS model and serial number are registered, complete and mail the enclosed postage-paid warranty card.

Technical Support

Chloride offers 24-hour technical support. To contact Chloride Service:

- North America: (847) 816-6000, option 3
or toll free (800) 327-8801, option 3.

Please check with Chloride Service for assistance ordering, replacing, or disposing of batteries. Please check with Chloride Service before attempting to repair or return any Chloride product. If a Chloride UPS needs repair or replacement, Service will issue a Return Material Authorization (RMA) number along with instructions on how to return the UPS.

FCC Compliance



ATTENTION: Changes or modifications to this unit not expressly approved by the party responsible or in FCC compliance could void the user's authority to operate the equipment.

This equipment was tested and complies with the limits for a Class A digital device, pursuant to Part 15 of FCC Rules. These limits are designed to provide reasonable protection against harmful interference when the UPS is operating in a commercial environment. The UPS generates, uses, and can radiate radio frequency energy. If installation and use is not in accordance with the instruction manual, it may cause harmful interference to radio communications.



ATTENTION: Operation of this equipment in a residential area may cause harmful radio communications interference. The user is responsible for correcting the interference.

Safety Compliance

UL listing to UL1778

TUV compliance to EN62040-1

CE

Safety Intended Use

This device serves as an uninterruptible power supply for connected loads. The device is in compliance with all relevant safety regulations concerning information technology equipment, including electronic machines for use in an office environment.

Depending on the type and rating of UPS device, certain configurations of battery extensions must be connected. These battery extensions may only be connected to the compatible basic UPS unit.

This system, henceforward the "unit", serves as uninterruptible power supply for connected loads, available for use in 19-inch racks. The 6 kVA and 10 kVA must be operated with at least one rack-mount battery extension. These battery extensions may only be connected electrically with the corresponding base UPS unit.



WARNING: Chloride considers the safety of personnel to be of paramount importance. For this reason it is essential that procedures relating to safety be studied before commencing work, and properly adhered to thereafter.

- The **User or Operator** may intervene in the operation of the UPS provided that the instructions laid out in “Batteries” on page 3, “Control Panel for the Linear Plus Rack-mount” on page 16 and “Indication and Operating Elements Linear Plus Rack-mount” on page 15 are strictly adhered to.
- The **“Installation”** of the UPS, described in “Installation” on page 7, may only be carried out by **qualified technical personnel**.
- Even when all switches and interrupters are open, hazardous voltages are present within the UPS; any operation that requires protection panels to be opened and/or removed must be carried out by **Chloride authorized technical personnel only**.

The Linear Plus Rack-mount Series UPS listed in Table 1 on page 4, with a mounting height of 3 U (1 U = 1.75” (44.45 mm)), are designed for horizontal installation in 19-inch racks of industrial standard.

Safety Notices



WARNING: Carefully read the following safety notices! Failure to observe the instructions may endanger your life, your health, the reliability of your device or the security of your data.

- Transport the unit only in suitable packaging (protected against jolts and shocks).
- If the equipment is moved from a cold environment to the operating room, condensation may occur. Before you switch on the equipment it must be absolutely dry. An acclimatization period of at least two hours is required.
- The equipment must be installed in accordance with the environmental conditions specified in “Environmental conditions” on page 5 and in Table 3 on page 8.
- Even with all buttons in “OFF” (see chapter “Control Panel for the Linear Plus Rack-mount” on page 16) the device (UPS) is **not** isolated from the mains. To isolate completely from the mains, the power cables must be disconnected.
- In case of interruption of the mains voltage, the integrated battery maintains the power supply to the user equipment.
- Lay all cables so that nobody can stand on them or trip over them. When connecting the device to the power supply, follow the instructions in the chapter “Installation” on page 7.
- Make sure that no objects (e.g. pins, necklaces, paper clips, etc.) inside the device.
- In emergencies (e.g. damaged case, controls or power cables, penetration of liquids or foreign matter) switch off the device and contact the appropriate customer service representative.
- Do not connect equipment that will overload the UPS (e.g. laser printers or vacuum cleaners) or demand DC-current (e.g. half-wave rectifiers).
- When cleaning the unit, follow the instructions in the chapter “Maintenance” on page 21.
- The sum of the leakage currents (protective conductor current) of the UPS and the connected devices exceeds 3.5 mA for all ratings of the UPS. Earth connection is essential before connecting supply.
- Data transmission lines should **not** be connected or disconnected during a thunderstorm.
- Emergency Power Off (EPO) input is located on the rear of the unit (see Fig. 5 on page 11). When this connection is open, the logic circuit will immediately shut down the UPS output.
- In order that the wiring installation safety comply to the European Harmonized Document HD384-4-46 S1, an Emergency Switching Device (E.S.D.) shall be fitted downstream of the UPS.
- When mounting the unit into a rack, it has to be hooked on both sides and the front plate of the unit has to be fixed to the rack by screws. The unit has to be fixed in horizontal position.
- Do not connect:
 - more than 5 external batteries to the Linear Plus Rack-mount 6 KVA.
 - more than 5 external batteries to the Linear Plus Rack-mount 10 KVA.
- The vents for air intake and outlet at the front and rear side must not be obstructed.
- Linear Plus Rack-mount UPSs are equipped with additional safety relays, that protect the input terminals in special cases.

Safety

Emergency



WARNING: The supply to the load may be interrupted by opening all the switches.

WARNING: DO NOT USE WATER to extinguish any fires that may occur in the area in which the UPS is installed.

Leakage Currents



WARNING: Connect the earth ground [protection earth (PE)] safety conductor before any other cables are connected.

Radio Interference

Linear Plus Rack-mount is a class A product.

The UPS device may cause radio interference. Do not place it near devices which are especially susceptible to electromagnetic interference (e.g. transmitters/receivers, radar, metal detectors, anti-theft devices).

Batteries

Battery maintenance must be carried out by authorized personnel.

- The batteries installed in external battery cabinets may contain electrolyte. Under normal conditions the containers are dry. A damaged battery may leak electrolyte which can be dangerous in contact with the skin and cause irritation to the eyes. Should this happen wash the affected part with copious amounts of water and seek immediate medical advice.
- Voltage is always present on the battery contacts.
- Even when discharged a battery has the capacity to supply a high short circuit current, which, in addition to causing damage to the battery itself and to associated cables, may expose the operator to the risk of burns.
- The voltage of a single cell of a single battery block is not dangerous. However a number of cells or battery blocks, connected in series, can produce hazardous voltages.
- The battery is a “hermetic” type battery and must not be kept in storage or disuse for periods exceeding 6 months at 68°F (20°C) without being recharged (having been charged to 100% at the beginning of any such period). If this period is exceeded it is essential that the batteries be recharged, which requires that the UPS be switched on. If these conditions are not respected the performance of the battery can no longer be guaranteed. We advise recharging the batteries at least once every 4 months.
- Since new batteries often do not provide full capacity after an initial charge it may be necessary to carry out a number of discharge/recharge cycles before optimum performance is achieved.
- In order to protect the environment batteries must be disposed of in accordance with the regulations governing disposal of toxic and harmful waste.

Repackaging

To re-pack, proceed as follows:

1. Do not pack the equipment until at least six hours have elapsed since the last recharge.
2. Place the equipment in bags made of a material sufficiently porous to allow it to breathe (e.g. 100µm polyethylene).
3. Do not remove air from the packaging.

Notes Regarding the EU Declaration of Conformity

The Linear Plus Rack-mount devices conform to the following European directives:

73/23/EEC

Directive of the council for adaptation of the legal regulations of the memberstates regarding electrical equipment for use within specific voltage limits, modified by directive 93/68/EEC.

89/336/EEC

Directive of the council for adaptation of the legal regulations of the member states regarding electromagnetic compatibility, modified by directive 91/263/EEC, 92/31/EEC and 93/68/EEC.

Conformity is established through compliance with the following standards:

- EN 62040-1-1
- EN 62040-2

Additional information regarding adherence to these directives is included in the appendices NSR and EMC of the EU Declaration of Conformity.

If required, the EU Declaration of Conformity can be requested from Chloride.

About the Operating Instructions

Introduction

This manual contains information regarding the installation, operation and use of the Uninterruptible Power Supply (UPS) Linear Plus Rack-mount.

It is advised that this User's Manual be consulted before installation of the equipment, which operation shall only be carried out by qualified personnel. Thereafter, it shall be kept and referred to whenever it is necessary to carry out work on the UPS.

Device Overview

The Linear Plus Rack-mount devices are available at various nominal power ratings.

The following table provides an overview of the various versions of the device:

Table 1. Overview of UPS devices and batteries (BP = Battery Pack)

Type	Designation	Order No.	Nominal Power
19" rack-mount UPS	Linear Plus Rack-mount 6 kVA	LP061XHR-	6000 VA
	Linear Plus Rack-mount 10 kVA	LP101XHR-	10000 VA
External Battery	Standard External Battery	LPBP100-2	NA

Symbols

The following symbols are used in this handbook:



WARNING: indicates instructions which, if not observed, may endanger your life, your health, the reliability of your device or the security of your data.

NOTE: Indicates additional information and tips.

Documentation Structure

These instructions can be supplemented with additional sheets, describing, for example, specific extensions, options or device status.

Preparation for Use

Delivery

The goods have been checked thoroughly before dispatch. On receipt check the packaging and ensure that the contents are undamaged. Any damage or missing parts must be reported to the supplier within 8 days of delivery.

Delivery and Storage

Unpacking

The utmost care shall be taken when removing the packaging in order to avoid damaging the equipment. Check all packaging materials to ensure that no items are discarded. Remove the packaging following the sequence illustrated in Fig. 1.



TOOLS KIT	
	PALLET JACK
	SCISSORS
	SCREWDRIVER

Fig. 1: Unpacking

Storage

If it is not intended that the UPS be used immediately upon delivery, attention shall be paid to the storage conditions.

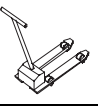
If the batteries or the equipment are to be stored, they must be kept in a clean, dry environment and away from extremes of temperature.

Table 2. Storage data

Temperature limits - Batteries ONLY	+32°F to +104°F (0°C to +40°C)
Temperature limits - UPS without batteries	-13°F to +131°F (-25°C to +55°C)
Relative humidity	from 10% to 90%

Handling

The equipment must be kept upright at all times and handled with care, damage may be caused if dropped or subjected to severe impact.

Environmental conditions

The Linear Plus Rack-mount UPS must be installed horizontally, and in an area protected from extremes of temperature, water and humidity and the presence of conductive powder or dust. (See Table 3 on page 8). Do not stack units and do not place any objects on top of a unit.

The functional temperature range of the UPS is 32°F to 104°F (0°C to 40°C).

The ideal ambient temperature range is 59°F to 77°F (15°C to 25°C). The maximum ambient operating temperature is 104°F (40°C).

The battery life is defined at 68°F (20°C). Operation of the equipment above 77°F (25°C) reduces the service life of the batteries dramatically.

Access to area

The area must have sufficient space for the installation operation to be carried out. Access doors must be sufficiently large to permit passage of the unit (See “Installation” on page 7).

Rack loading

Taking into consideration the weight of the Linear Plus Rack-mount UPS/batteries as reported in Table 5 on page 9, it is necessary that the chosen cabinet be capable of supporting the weight of the unit / batteries.

Inventory list

- Parallelable UPS types are equipped with
(1) control cable, 25-pin
(1) jumper for terminals S1-S2
- Linear Plus Rack-mount UPS contains (1) jumper for disabling the EPO circuit when not in use.
- Battery cabinets/racks contain (1) DC-power cable
- Linear Plus Rack-mount devices are equipped with (1) set of rails and rail guides (Fig. 2 on page 6)
- UPS devices only contain (1) user manual

Mechanical fixing of 19 inch units

Selection of the mounting location

NOTE: The Linear Plus Rack-Mount UPS and its battery racks are designed to be mounted horizontal in 19-inch racks. When installing the units please consider the weight, especially of the battery extension. Preferably the units should be installed in the lower section of the rack. UPS systems consisting of several units must be installed so that the battery extensions are mounted in the lower section of the rack with the UPS directly above.

Included in each Linear Plus Rack-Mount carton is a rail kit, part number 301-170. The Rail Kit consists of the following components:

- Rail, left front, part number 203-710
- Rail, right front, part number 203-711
- Rail, rear, part number 203-645 (2 each)
- Bag, hardware part number 360-020
- Bag, hardware part number 360-021

Before beginning installation, be sure all parts are identified.

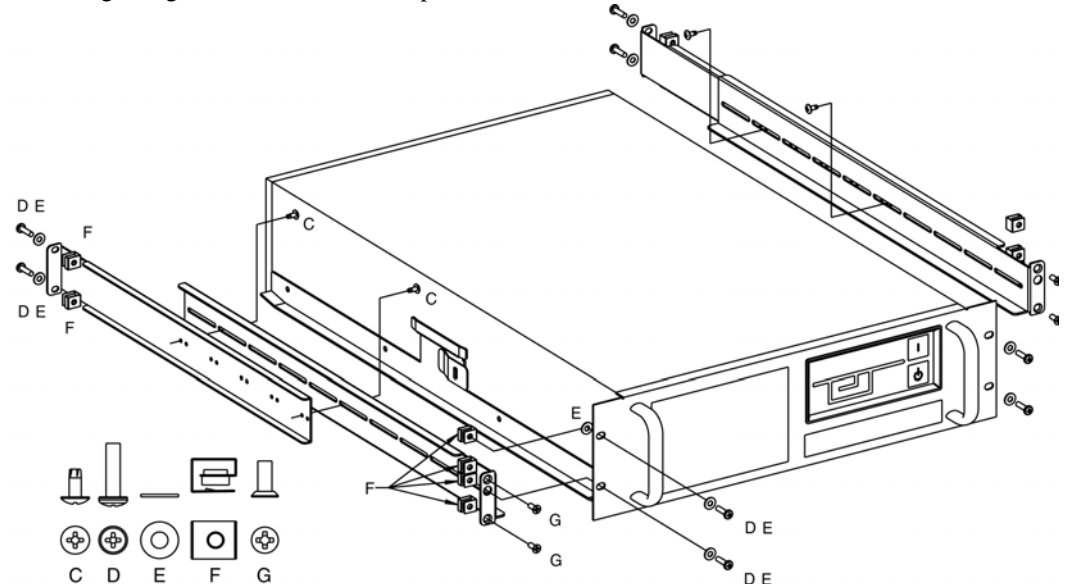

LTR	DESCRIPTION	# REQ.
C	#8-32 TRUSS HEAD THREAD CUTTING SCREW, 3/8" LONG	4
D	#10-32 PAN HEAD SCREW, 3/4" LONG	8
E	#10 FLAT WASHER	10
F	#10-32 CLIP NUT, G - TYPE	12
G	#10-32 FLAT HEAD SCREW 1/2" LONG	4

Fig. 2: Rack Kit Installation

1. Using Fig. 2, assemble the left rail and right rail guides. Leave enough slack to permit final alignments in the rack.

2. Position the left and right rail guides in the four-post rack and tighten all fasteners.

CAUTION: The rail guide for the lowest battery cabinet should be installed first at the lowest position in the rack. Once the first battery is installed, then subsequent battery rail guides should be installed above. The final rail guide assembly, located above the last battery cabinet, should support the UPS cabinet at the top.

3. Using Fig. 3, assemble the mounting rails to the body of the UPS or battery extension.
4. Slide the Linear Plus battery chassis, with its left and right hand channels attached, onto the rail guide until the front of the chassis is in contact with the front of the rail guide.
5. Fasten the chassis to the rack as shown in using the screws (D) and flat washers (E).

Repeat for each subsequent chassis.

When all of the chassis units are securely in the rack continue with the electrical installation. See “Electrical Preparations” on page 7.

The units must be secured in the rack on both sides. When using the UPS attached mounting rails (see Fig. 3 below), the single unit can easily be inserted into a 3 U mounting space. In order to secure the unit in the horizontal position, the front-plate has to be secured to the 19-inch rack at the indicated points on both sides of the unit. It is not permissible to secure the unit only at the front-plate. This may damage the unit and/or other mounted units.

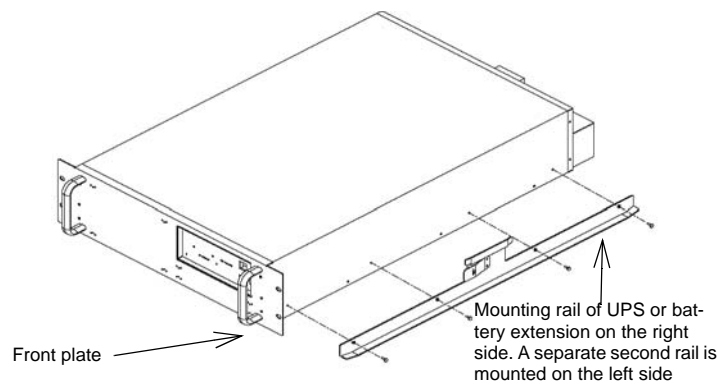

Fig. 3: Mounting the rails to the body of the UPS or battery extension

Installation

Electrical Preparations

During installation the input source must be isolated and secured against the possibility of being reconnected. The Input miniature circuit breaker located at the rear of the UPS and both circuit breaker poles of the battery cabinet(s) must be in “OFF” position. Connect the UPS and battery cabinet(s) according to these instruction.

NOTE: It must be ensured that the live input source cannot accidentally be connected to the UPS during installation.



WARNING: Installation may be carried out only by qualified technicians and in conformity with the applicable safety standards.



WARNING: Electrical shock hazard: Even when the unit is disconnected from the mains, hazardous voltage may still be supplied by the battery. Both circuit breaker poles should, therefore, be disconnected before carrying out maintenance or installation work inside the UPS.

For electrical installation, the nominal current rating of the source must be observed. The UPS must be connected to a suitably rated circuit.

Installation Data

Table 3. Environment data

Ambient temperature	+32°F to +104°F (0 °C to +40 °C)
Relative humidity (w/o condensing at 20°C)	90%
Max. altitude (w/o derating)	1000 m a.s.l.
Cable inlet	bottom at the rear side
Air inlet	front
Air outlet	rear

Table 4. Electrical data Linear Plus Rack-mount 6 kVA/10 kVA

UPS-TYPE		Linear Plus Rack-mount 6 kVA	Linear Plus Rack-mount 10 kVA
Electrical Data			
Rating		6 kVA	10 kVA
Input	Voltage	208, 220, 230, 240 VAC, 1 phase	
	Frequency	50/60Hz ± 5%, automatic frequency sensing	
	Current @ 208 VAC	29 A	48 A
Battery external	Type ^a	External battery packs only (1 to 5 packs)	External battery packs only (1 to 5 packs)
	Voltage/Ah Type	240V/ 20x (12V/8 Ah) Yuasa Rew 45-12FR	
Output	Voltage	208, 220, 230, 240V ± 2%	
	Frequency with mains control	see input frequency	
	Frequency with internal clock	50/60Hz ± 0.5%	
	Nominal current at cos φ = 0.7 and 208 V	28.8 A	48 A
General			
Over voltage category		II	
Protection class		IP 20	
Cooling		Ventilator	
a. use battery type for replacement purpose also. No other type permitted			

conduits or that shielded cables be used. Routing of cables (e.g. power supplies, communication or data lines) to other equipment, should be kept separate from that of UPS cables.

Neutral Connection

The installation of the UPS does not affect the existing Neutral system.

The Neutral system may be affected if the UPS is operating with the Neutral switched upstream.

External Protection and Isolating Devices



WARNING: A disconnect switch shall be provided by others for AC input/output circuit. To reduce the risk of fire, connect only to a circuit provided with branch circuit over current protection for Table 7 Amperes rating in accordance with the National Electric Code, ANSI/NFPA 70.

The following table indicates the protection devices (circuit breakers and fuses) which must be installed by the installing personnel for protection of both the cables and the equipment.

Table 7. Fuses or circuit breakers

UPS Type		Linear Plus Rack-mount 6 kVA	Linear Plus Rack-mount 10 kVA
Input	Fuse / A	40 A	60 A
	Circuit breaker / A	40 A	60 A
Output	Circuit breaker	30 A	50 A

NOTE: The external battery cabinet shall be located adjacent to the UPS. When such an option is supplied by Chloride it comes complete with protection devices and correctly-sized cables. When batteries are sourced from other suppliers it is advised that Chloride be contacted for correct sizing of protection devices and interconnection cables.

Installation of Differential Protection Devices

Fig. 4 illustrates the method of installing differential breakers.

To avoid spurious operation, differential protection devices must:

- be rated at differential current NOT LESS THAN 100 mA
- be a SELECTIVE type (delayed intervention)
- be Type A

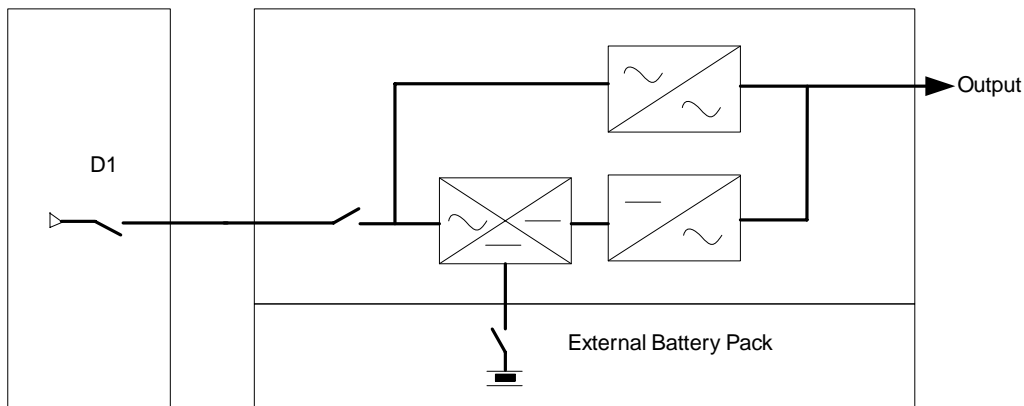

Fig. 4: Standard configuration

Terminal Blocks for UPS

The following figures show the units with the external battery extension.

To connect the external battery to the UPS, plug the battery cable (16) into the socket (9) and into a battery extension socket (13).

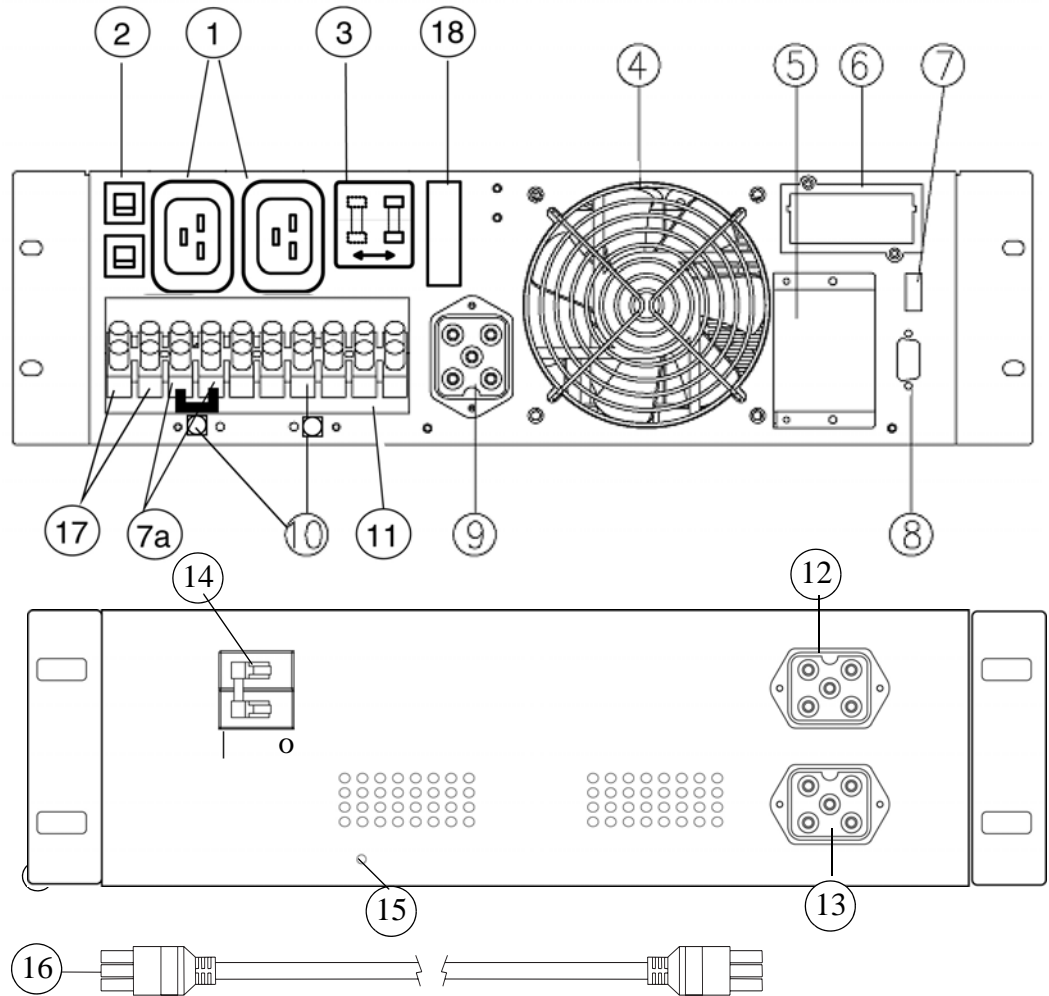

Fig. 5: Rear View Linear Plus Rack-mount UPS (top), Battery (center), and Cable (bottom)

Legend:

- | | |
|---|---|
| 1. Output socket(s) IEC 320 - C19 | 11. Mains connection, Terminal Block |
| 2. 2 Output circuit breaker (for plugged outlets) | 12. Battery socket for battery connection cable to UPS |
| 3. Input miniature circuit breaker | 13. Battery extension cable socket. Connected to UPS or another battery extension |
| 4. Fan | 14. Battery extension circuit breaker |
| 5. Cover of parallel port | 15. Earth connection |
| 6. Communication Slot (Option) | 16. Battery extension connection cable |
| 7. ESD Contacts (control) | 17. S1, S2: Paralleling terminals (bridged 10 mm ² if UPS works in single block mode, open if UPS in parallel operation) |
| 7a. ESD Contacts, hardwired | 18. Terminals for backfeed control |
| 8. UPS interface COM 3 | |
| 9. Battery socket | |
| 10. Strain relief | |

NOTE: Each external battery cabinet is supplied with one battery connection cable (16). The first

extension is connected to the battery connection the UPS (9), each subsequent extension is connected by means of the battery extension connection cables (16). The cables are designed to be non-interchangeable, because the sockets (13) are coded.

Connecting Mains

Connect the mains supply to the input terminals of the UPS (see Fig. 5 on page 11 and Table 6 on page 9).

Connecting parallel UPS configurations: refer to chapter “Paralleling UPS Devices” on page 19.

Connecting Load Cables

1. Open UPS input breaker.
2. Remove terminal area safety cover.
3. Connect loads to “Output” terminals (see Fig. 5 on page 11 and Table 6 on page 9).
4. Connect mains to the corresponding input terminals (see Fig. 5 on page 11 and Table 6 on page 9).

Preparing single mode / parallel mode:

- If UPS is to be operated as single unit connect a 6 awg (10 mm²) jumper between S1 and S2.
- If UPS is to be operated as parallel unit ensure that no jumper is connected between S1 / S2.

External Battery Connection



WARNING:

•The batteries installed in external battery cabinet may contain electrolyte. Under normal conditions the containers are dry. A damaged battery may leak electrolyte which can be dangerous in contact with the skin and cause irritation to the eyes. Should this happen wash the affected part with copious amounts of water and seek immediate medical advice.

•Do not open or damage batteries. The released electrolyte is toxic.

•Voltage is always present on the battery contacts.

•Even when discharged a battery has the capacity to supply a high short circuit current, which, in addition to causing damage to the battery itself and to associated cables, may expose the operator to the risk of burns. The following precautions should be observed when working on batteries:

- Remove watches, rings or other metal objects.
- Use tools with insulated handles.

•The voltage of a single cell of a single battery block is not dangerous. However a number of cells or battery blocks, connected in series, can produce hazardous voltages.

•The accumulator is a “hermetic” type battery and must not be kept in storage or disuse for periods exceeding 6 months at 68°F (20 °C) without being recharged (having been charged to 100% at the beginning of any such period). If this period is exceeded it is essential that the batteries be recharged, which requires that the UPS be switched on. If these conditions are not respected the performance of the battery can no longer be guaranteed. We advise recharging the batteries at least once every 4 months.

•Since new batteries often do not provide full capacity after an initial charge it may be necessary to carry out a number of discharge/recharge cycles before optimum performance is achieved.

•When replacing batteries, replace with the same type and number of batteries and battery packs.

•In order to protect the environment batteries must be disposed of in accordance with the regulations governing disposal of toxic and harmful waste.

•Do not dispose of batteries in a fire. The batteries may explode.

Before Connecting the UPS and the external battery cabinet, check to see that the battery breaker is in the “OFF” position.

The battery connection cable plug is keyed to the receptacles on the UPS and battery cabinet. Insure that the plug notch is correctly aligned with the receptacle guide when connecting the components together.

Auxiliary Backfeed Protection

To support protection against UPS backfeeding logic is integrated into Linear Plus Rack-mount.

Using backfeed protection

On customers side an additional magnetic contactor (MC) may be provided. The magnetic contactor must be able to carry the UPS input current (see table Table 4, “Electrical data Linear Plus Rack-mount 6 kVA/ 10 kVA,” on page 8).

The MC has to be installed in the common input supply path. Cabling of the backfeed terminals contains a jumper and two cables to the optional magnetic contactor.

Not using backfeed protection

For cabling the backfeed terminal board, please follow Fig. 6.

The factory setting of the backfeed terminal board, located on the UPS rear side, is shown there .

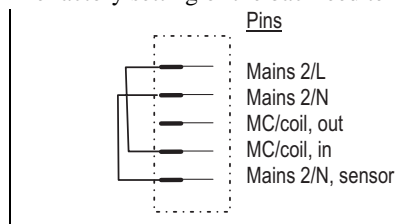

Fig. 6: Backfeed terminal board, factory setting

Operation

If bypass thyristor is shorted (short circuit) and UPS runs in double conversion mode (online) the following steps follow:

- the backfeed detection circuit activates, backfeed relay opens.
- Press the “o” button to acknowledge the fault.

Reset

To reset the backfeed logic the UPS input circuit breaker/battery circuit breaker must be switched “OFF” for 10 seconds

Operating the Device

Normal and Safe Operating

Block diagram Linear Plus Rack-mount

Linear Plus Rack-mount 6 kVA and 10 kVA consists of the following main components

- mains supply
- input switch
- rectifier/booster, inverter and charger
- electronic bypass
- paralleling contactor
- RPO hardwired
- backfeed protection logic
- Battery racks are external.

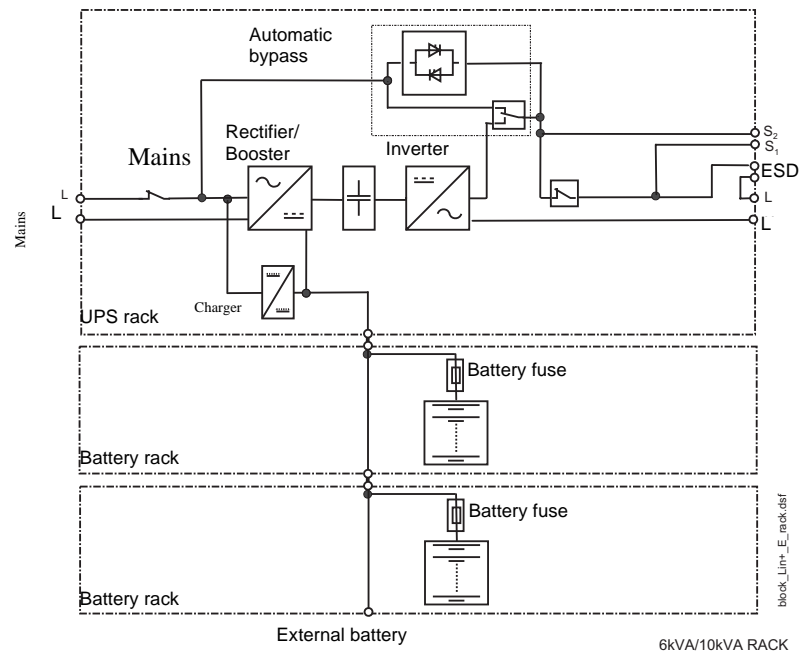

Fig. 7: Overview of components Linear Plus Rack-mount 6 kVA/10 kVA

Preliminary controls

Before switching on the UPS and supplying the load the following shall be observed:

- Ensure that the ventilation grilles are unobstructed.
- Ensure the ground (earth) connection is in place.
- Ensure that the load switches are in the OFF (0) position.
- Ensure that all UPS rear panel switches are in the OFF (0) position.



WARNING: As soon as the UPS is connected to the AC mains, the output sockets are live, even if the UPS is not yet switched on via the front panel switch.

1. Switch ON the mains supply to the UPS Linear Plus Rack-mount.

When connected to the mains, the “LINE” and “BYPASS” LEDs on the control panel are illuminated and the UPS starts recharging the connected (external) batteries immediately. Before using the device, the batteries should be recharged for a period of 8 hours. The UPS may be used immediately, even without charging, but will not be able to provide the specified autonomy.

2. Once recharging has been completed the UPS is ready for use, follow the UPS Start-Up Procedure - see “UPS Start-Up Procedure” on page 14.



WARNING: Do not connect any devices that may overload the UPS or draw DC current.

NOTE: If these instructions are not observed correctly, problems may be experienced with the electrical supply.

UPS Start-Up Procedure

1. Ensure all the mains switches and circuit breakers upstream of the UPS are closed.
2. Ensure batteries are connected.
3. Switch the battery breaker to the closed (|) position.
4. Switch input breaker to “ON” position (|).
5. The unit will go through a self-test. Wait for the yellow BYPASS LED to illuminate (approximately 15 seconds).

6. Close any external switches connecting the load (if present).
7. Press the button  on the UPS control panel for a minimum of 1 second to switch on the inverter (see “Control Panel for the Linear Plus Rack-mount” on page 16).

In addition to the “LINE” and “BYPASS” LEDs the “LOAD” LED and “BATTERY” LED is now illuminated. After a few seconds the “INVERTER” LED is illuminated and the “BYPASS” LED is extinguished. The UPS is now in ON-LINE operation.

UPS Shutdown Procedure

NOTE: Carrying out this procedure will interrupt the supply to the load.

1. Press the button  on the UPS control panel for a minimum of 1 second to switch off the inverter.
2. Open any external switches connecting the load (if present).
3. Switch input breaker to position (0) OFF.
4. Switch off the battery breaker. to the open (O) position.
5. Ensure all mains switches and circuit breakers upstream of the UPS are open.
6. Ensure that all LEDs on the control panel are extinguished. The UPS is now completely shutdown.

Functional Test

NOTE: Supply to the load is not guaranteed during this test, it should not be carried out if a critical load is connected to the UPS.

It is possible to carry out a functional test of the UPS to ensure that the load is still supplied in the event of a mains failure.

Simulate a mains failure by interrupting the mains supply to the UPS. If the UPS is operating correctly and the batteries are fully charged, an acoustic signal at intervals of 4 seconds will be heard and the “ON” LED indication “MAINS “indicator (6) at the UPS will be extinguished. Once the interval between the acoustic signals has decreased to 1 second, the UPS will continue to supply energy for a maximum of 3 more minutes, after which it will be automatically switched off.

The load will be supplied from the batteries during the specified emergency supply period. If this is not the case, please consult chapter “Troubleshooting” on page 25”.

Restore the UPS mains supply. The UPS is ready for operation. Please note, that the batteries have to be recharged before the complete emergency supply period is again available.

NOTE: The unit indicates an alarm condition, when the battery is not connected.

Canceling the battery alarm

1. To cancel the alarm, connect the battery and close the battery breaker.
2. Switch the unit to online mode by pushing the button .

The unit checks the battery voltage (a beep is heard) once more and stays in bypass till a constant battery voltage is present.

Battery maintenance must be carried out by authorized personnel observing the necessary precautions.

Parallel operation

Please refer to chapter “Paralleling UPS Devices” on page 19

Indication and Operating Elements Linear Plus Rack-mount

NOTE: To effect any action, the buttons must be pressed for at least 1 second! (Acceptance of the input is confirmed acoustically)

The following is an explanation of the symbols printed on the front panel of the UPS:

Indication and Operating Elements

Control Panel for the Linear Plus Rack-mount

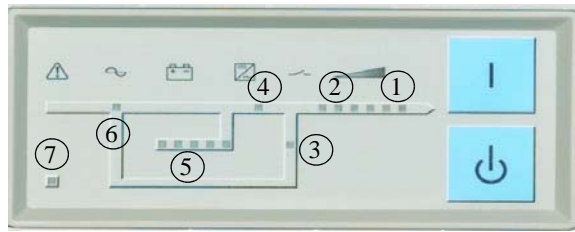

The **OVERLOAD** indicator, red, (1) illuminates if the UPS is overloaded.

The **LOAD** LED strip (2) displays the load status of the UPS. See Table 8 on page 17 for details.

The **BYPASS** indicator, yellow, (3) illuminates when the UPS delivers voltage supplied from the mains supply via the bypass.

The **INVERTER** indicator, green, (4) illuminates when the inverter is running.

The **BATTERY** LED chain, green, (5) indicates the charging state of the battery (normal operation). See Table 9 on page 17 for details.

The **MAINS** indicator, green, (6) illuminates when normal mains voltage is present at the UPS input.

The **ALARM** indicator, red, (7) illuminates to indicate a UPS fault. An acoustical warning signal is activated simultaneously; this signal is reset when the UPS is switched off.

The  button switches the inverter Off and the bypass On.

The  button switches the inverter On (bypass Off).

The inverter is activated by pressing the  button. Following a delay time of approximately 5 seconds, the **BYPASS** indicator extinguishes and the **INVERTER** indicator illuminates.

Pressing the  button, blocks the inverter and switches the system to bypass. **UPS output voltage is present.**

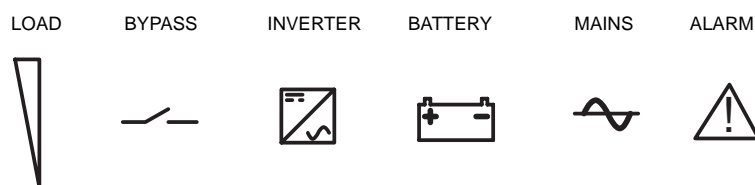

Fig. 8: Symbols on the control panel of the UPS Linear Plus Rack-mount

The UPS indicates, by acoustic (buzz) and optical (LED) alarms, that a mains failure has occurred and is still present. Different procedures, described below, may be followed to interrupt work in case of a persistent mains failure.

Which of the procedures is applied depends, primarily, on the time required to close the program safely and - if necessary - for an organized shut down of the operating system.

For example, work on a PC, which is individually supplied by the UPS, may be continued until the battery nears minimum charge level. The buzzer indicates the mains failure periodically (every 4 seconds) and, when minimum charge level is neared, once a second. This procedure is not often adopted. Although battery recharge starts immediately when the mains is re-established, it can take several hours to recharge the battery fully.

The situation can better be analyzed by using the UPS load LEDs, which indicate the remaining autonomy for a constant load. The following table shows the approximate autonomies in case of a fully charged battery at the beginning of the mains failure.

Table 8. Backup time according to load indication (standard devices with batteries integrated)

	load in %	6 kVA/10 kVA	LED Color
Overload	>105		red
load	95-105	6 min /5 min	yellow
	75-95	9 min	green
	55-75	17 min	green
	30-55	31 min	green
	1-30	60 min	green

The current battery capacity can be read from the LED chain **BATTERY** (see table below).

Table 9. Battery capacity according to LED chain “battery”

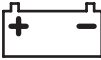
	Battery capacity in %	LED Color
	1-35	green
	35-55	green
	55-75	green
	75-95	green
	95-100	green

The most reliable method, however, is the use of either MopUPS[®] Professional UPS software or a ManageUPS[®] network adapter. With these tools, the projected remaining battery capacity is indicated both before and during a mains failures. Furthermore, shutdown procedures can be automated. Depending on the application program, operating system and computer hardware, it can be ensured that in the event of a mains failure the application programs are automatically closed, the subscribers logged in at the server are logged out, data is stored, and the operating systems are shut down. For further information please refer to our publication about the Chloride connectivity solutions.

Once the mains voltage returns, the UPS will restart in the preset mode. Depending on the installed software, the computer’s status before the mains failure can be re-established.

In the event of overload or internal failure, the load is transferred to the mains via an automatic bypass, without interruption. As soon as normal conditions are re-established, the unit switches automatically to the inverter.

Operating modes Linear Plus Rack-mount

The UPS has three different operating modes when it is switched on.

Normal operation (mains supply present)

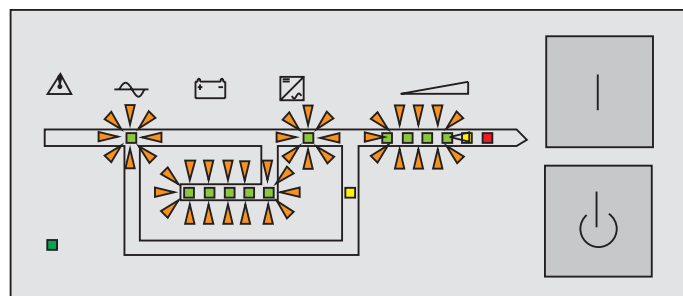

Fig. 9: UPS Control Panel: “Normal Operation”

The loads are supplied directly from mains via the inverter. Loads are protected against mains failures and disturbances.

Battery operation (mains failure)

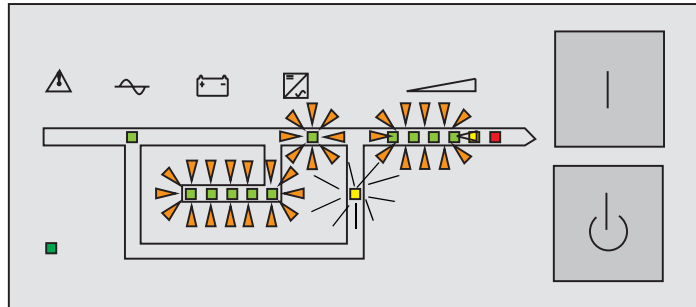

Fig. 10: UPS Control Panel: “Battery Operation”

In the event of a mains failure, the inverter supplies the loads without interruption; the power is supplied by the battery.

In this operating mode, an acoustical sound is emitted at intervals of approximately 4 seconds. If the minimum power level of the battery is reached, the signal is emitted once a second.

Bypass operation (overload > 100%, < 150%),for

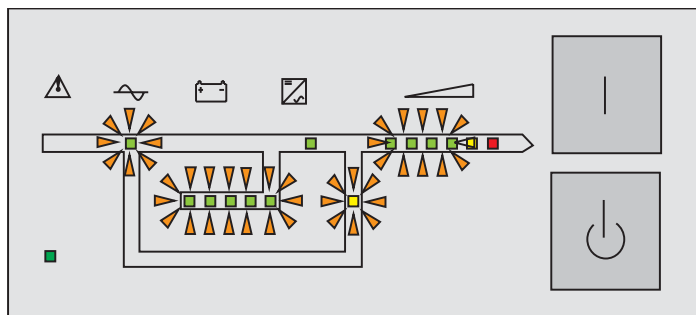

Fig. 11: UPS Control Panel: BYPASS Operation

In the event of an overload between 105% and 150% of rated capacity, the device switches to bypass and the inverter is blocked. Power is supplied by the mains supply.

This is not a normal operating state. If the mains supply fails, the loads will no longer be supplied (no UPS operation).

NOTE: For sustained overloads > 130% of capacity, the output will be disconnected within one hour to protect the circuitry from overheating.

Parallel operation

Refer to chapter “Paralleling UPS Devices” on page 19.

Remote Power Off (RPO)

For reasons of safety it is required that UPS Emergency Power Off be effected by removing the connections between the RPO terminals located on the rear of the UPS next to the Interface COM 3 connector Fig. 5 on page 11 and connecting a switch, having the characteristics of an emergency button, closed under normal operating conditions and held open mechanically when operated. Once the emergency condition causing the switch to open has been resolved, open all UPS switches (Input, Output and Battery) and carry out Switch-on procedure as described above “UPS Start-Up Procedure” on page 14).

Emergency Power Off (ESD hardwired)

This Linear Plus Rack-mount UPS is equipped with separate terminals for connecting hardwired customer protection ESD relays. See block diagram Fig. 7 on page 14 for connection details.

Paralleling UPS Devices

A maximum of 3 Linear Plus Rack-mount UPSs can be connected in parallel. The units to be connected in parallel must be of the same type and rating and the settings of these devices must be identical.

General

The units configured as a parallel system may use only common mains supply.

Designing a Parallel System

When connecting mains and loads to a parallel UPS Linear Plus Rack-mount system additional distribution has to be taken into account.

A system of 2 parallel UPS blocks can be connected directly to the distribution if the system load doesn't exceed the nominal power of the UPS block (configuration: half load, 2 block parallel system)

If the supported load is greater than 50% of the total paralleled UPS load, it is suggested that an external maintenance bypass be installed.

Parallel System, Installation and Operating

First step

1. Ensure, that the mains supply distribution is switched "OFF".
2. Ensure that all the mains input breakers are switched to "OFF" on all UPSs. All terminals, breakers and plugs of UPS can be found the respective rear panels of UPS/batteries. Related figures: see Fig. 5 on page 11.

Second step

1. Remove jumper from Parallel Terminals (S1, S2) from each UPS terminal block (each UPS).
2. Connect the input terminals of all UPS blocks to the mains distribution. See Figure 12 on page 20.

3. Connect the UPS output terminals to the load distribution.

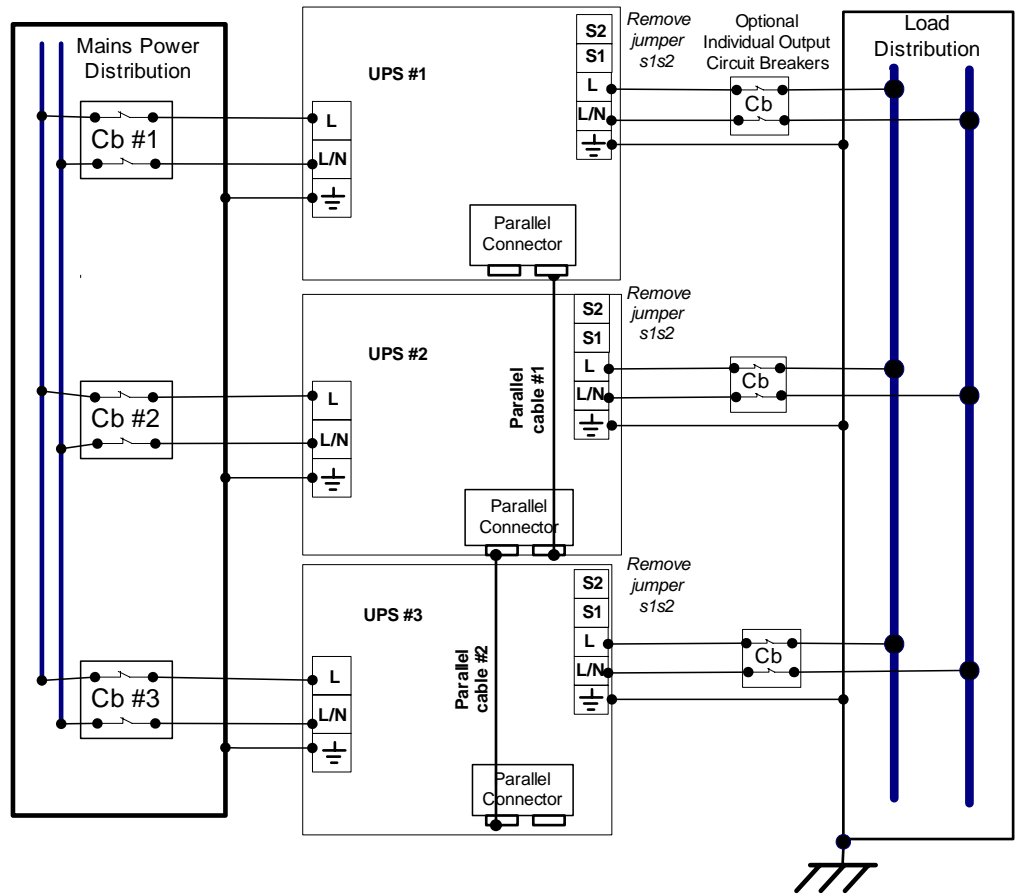



Fig. 12: Linear Plus Parallel Diagram

Third step

1. Remove cover of the parallel port of all parallel devices for linking between the UPS
2. Use the 25 pin standard control cable (supplied with UPS) to connect from one of the parallel ports.

NOTE: Parallel UPS are connected in line, not in a circle, i.e.: 2 cables connect 3 UPS units, 1 cable connects 2 UPS.

Fourth step

1. Close all the input breakers of all parallel UPSs.
2. Close all battery breakers on all extension battery cabinets to the “|” position.
3. Close the mains circuit breakers to each of the UPSs.
4. The unit will initiate a self-test for approximately 15 seconds. Wait for the yellow BYPASS LED to illuminate.
5. Press the button  on the first UPS control panel for a minimum of 1 second.
6. Repeat the UPS start-up procedure (step 5) on the second and on third UPS, if present. At this point all the bypass indicators are extinguished. All inverter indicators illuminate indicating that all parallel UPS inverters are running. The load is spread evenly across all the UPSs.

In addition to the “LINE” and “BYPASS” LEDs the “LOAD” LED is now illuminated. After a few seconds the “INVERTER” LED is illuminated and the “BYPASS” LED is extinguished. The UPS is now in ON-LINE operation. The load is spread evenly across all the UPSs.

NOTE: In a parallel system, on the unit that has been requested to transfer from bypass to on-line operation (steps 4 and 5), the battery display will pulse illuminate from right to left and the load display will pulse illuminate from left to right. This indicates the system is waiting for the other UPS system synchronize to the first unit. It is critical that after pushing the “|” button on the first UPS that the second/third Unit(s) also follows within 1 minute of starting the first UPS. Otherwise, the system that did not respond within the time allowed will shut down with a parallel fault. See “Troubleshooting” on page 25.

Maintenance

Test, Replacement and Disposal of Batteries

The UPS does not require maintenance by the user, however, battery maintenance is recommended in accordance with IEEE Recommended Practice for Maintenance, Testing and Replacement of Valve-Regulated Lead-Acid (VRLA) Batteries for Stationary Applications (IEEE Std 1188-1996). When the batteries expire, trained battery service personnel must replace them. A certified disposal/recycling company should carry out disposal / recycling of the UPS and / or batteries. Exhausted rechargeable batteries are classified as “harmful toxic waste” and as such the law demands that they be disposed of / recycled by an authorized recycling center.

The manufacturer’s service center is fully equipped to deal with such batteries, in accordance with the law and with the greatest respect for the environment. Contact Technical Support to arrange for maintenance and/or battery replacement.

The typical battery life cycle is 3 to 5 years, at an ambient temperature of 77°F (25°C), however battery life is also dependent on the frequency and duration of mains failures or battery discharge cycles.

The battery test should be carried out periodically (6 to 12 months) in order to ascertain the general condition of the batteries.

Battery Replacement



WARNING: Prior to starting the battery replacement, please read the entire instructions for important safety procedures.

NOTE: To obtain new battery(ies), contact Chloride Technical Services at 847-816-6000, toll free at 800-879-5011 option 3.

NOTE: The UPS cannot protect against power outages while the batteries are disconnected.



WARNING:

- External batteries can be replaced during “normal operation” of the UPS by a trained technician. However, the batteries must not be changed when the UPS is in the status “AC Fail = On Battery”. The UPS devices Linear Plus Rack-mount 6 and 10 kVA have no internal battery. For these units the AC power won’t be maintained when an AC Failure occurs during replacement of the first battery pack!
- Servicing of batteries should be performed or supervised by personnel knowledgeable about batteries and the required precautions.
- The batteries installed in the UPS and in the external battery cabinets contain electrolyte. Under normal conditions the containers are dry. A damaged battery may leak electrolyte that can be dangerous in contact with the skin and cause irritation to the eyes. Should this happen, wash the affected part with copious amounts of water and seek immediate medical attention.
- When replacing batteries, replace with the same type and number of batteries or battery packs.
- Do not dispose of batteries in a fire. The batteries may explode.
- Do not open or damage the battery cases. Released electrolyte is harmful to the skin and eyes and may be toxic.
- A battery can present a risk of electrical shock and high short-circuit current. The following precautions should be observed when working on batteries:
 - Remove watches, rings or other metal objects
 - Use tools with insulated handles
 - Wear rubber gloves and boots

- Do not lay tools or metal parts on top of batteries
- Disconnect charging source prior to connecting or disconnecting battery terminals
- Determine if the battery is inadvertently grounded. If inadvertently grounded, remove source from the ground. Contact with any part of a grounded battery can result in electrical shock. The likelihood of such shock can be reduced if such grounds are removed during installation and maintenance (applicable to equipment and remote battery supplies not having a grounded supply circuit).

Storage

For extended storage at ambient temperature <math><77^{\circ}\text{F}</math> (<math><25^{\circ}\text{C}</math>) the batteries should be charged for 5 hours once every 4 months, at higher storage temperatures it is advised that this period be reduced to 2 months.

1. Connect the UPS (with attached external battery cabinets) to a mains outlet socket having an earth connection or install fixed connections (in accordance with chapter "Installation" on page 7) to an appropriate source.
2. Switch on the input miniature circuit breaker at the rear of the devices (UPS and external battery cabinet) in the case of fixed connections.
3. After 5 hours, unplug from the mains supply or switch off the input miniature circuit breaker of the UPS in case of fixed connections, and switch off the circuit breaker of the external battery cabinet.
4. Remove the UPS and external battery cabinet connections in the opposite sequence to that described in "Installation".
5. Note the date recharging was carried out on the packaging of the external battery cabinet.

Cleaning

NOTE: Do not use scouring powder or plastic-dissolving solutions to clean the UPS.

1. Switch off the UPS by pressing the OFF button following the shutdown procedure and disconnect from the mains supply.
2. Make sure that the air vents on the UPS are not obstructed.
3. Remove dust from the air vents with a vacuum cleaner.
4. Clean the outside of the UPS housing by wiping with a dry or a slightly damp cloth.

NOTE: Do not allow liquid to get inside the UPS.

Interfaces

The Linear Plus Rack-mount is equipped with a serial interface COM 3 and an interface slot COM.

These interfaces can be used for:

- Direct communication between UPS and a workstation/server
- Integration of the UPS as client into a network with centralized monitoring via a ManageUPSNET II SNMP adapter to put in slot COM
- Transfer of operational states to external alarm systems via voltage-free contacts: with interface card SIC to put slot COM

The necessary communication software packages and interface cables are available as options.

Serial Interface COM 3

The 9-pole SUB-D connector (pin contacts) contains RS 232 compatible signals.

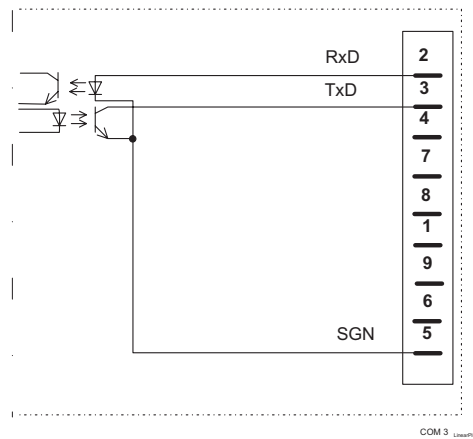

Fig. 13: Serial interface COM 3

The interface COM 3 is galvanically isolated from primary UPS circuits.

SGN at pin 5

Signal ground.

RXD at pin 2 and TXD at pin 3

Receive and transmit RS 232 compatible signals.

Optional Isolated Contacts Card

Below are the descriptions of the interface signals for the isolated contacts card that may be installed into the COM slot. This optional card provides potential-free signaling contacts and a shutdown input.

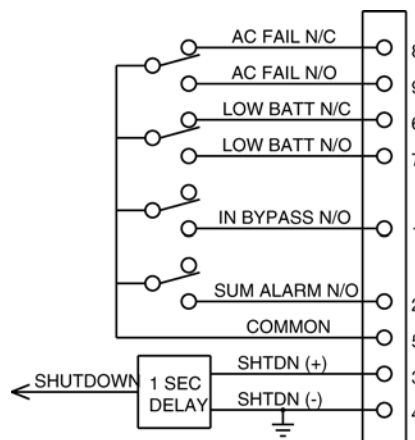

Fig. 14: Isolated Contacts Card Interface Signals

INV SHUTDOWN

This input (pin 3) is enabled with a high signal (+5 V to +12 V with respect to pin 4 (0 V)) and when enabled, switches off the UPS after a mains failure has occurred. After the mains have been reestablished, the UPS starts again independent of this signal status. This input must be high for one (1) second before shut off will occur.

AC FAIL

This output provides an N/O (Normally Open) contact between pins 9 and 5, and an N/C (Normally Closed) contact between pins 8 and 5. The 9-5 contact closes when the mains voltage fails at the UPS input or when the mains voltage falls below the lower limit for a minimum of 10 seconds. This contact opens approximately 850 ms after the mains have been reestablished. The 8-5 contact provides a mirror function, opening when the mains voltage fails and closing when main power returns.

LOW BATT

This output provides a N/O contact between pins 6 and 5 and an N/C contact between pins 7 and 5. The 6-5 contact closes when the battery has been depleted to the point that it can only supply current for approximately three (3) more minutes at nominal load. The 7-5 contact provides a mirror function opening when the battery is low.

BYPASS ACTIVE

This output provides an N/O contact between pins 1 and 5. The 1-5 contact closes after switching to the bypass mode. In the bypass mode, energy to the output of the UPS is being supplied by the mains power and not through the inverter.

SUM ALARM

This output provides an N/O contact between pins 2 and 5. The 2-5 contact closes when one of the alarms “AC FAIL,” “LOW BATT” or “BYPASS ACTIVE” is active or when the indication “ALARM” at the front-panel is on.

Troubleshooting

If, in spite of the high reliability of this device, problems should occur, please check the following points before contacting the responsible customer service representative:

- Is the mains voltage present at the UPS input?
- Is the input fuse blown or have circuit breakers tripped?
- Has UPS start up procedure been followed completely?

If you contact the responsible service representative, please have the following information ready:

- Device information = model
- Order no.
- Consult the label on the left front of the unit.
- Series number as per nameplate
- An exact description of the problem (what loads are being operated, does the problem occur regularly or sporadically etc.)

For description of the indicators mentioned below see chapter “Control Panel for the Linear Plus Rack-mount” on page 16.

Table 10. Troubleshooting

Problem	Possible cause	Measure
No display No alarm (UPS switched off)	Mains switched off	Switch on mains switch
	No mains voltage present	Have mains inspected by qualified electrician
	Input circuit breaker tripped	Reset circuit breaker. If the problem persists, contact the responsible customer service representative.
MAINS indicator does not illuminate, acoustic alarm active at intervals	No mains voltage present	UPS operation “Operating modes Linear Plus Rack-mount” on page 17
MAINS indicator does not illuminate when mains voltage present, acoustic alarm active at intervals	Input circuit breaker tripped	Reset circuit breaker. If the problem persists, contact the responsible customer service representative.
ALARM indicator illuminates, acoustic alarm active continuously	UPS error	Contact the responsible customer service representative
	Overheating	Decrease ambient temperature
Autonomy less than specified	The fuse switch of the battery extension(s) is in the “OPEN” position.	Move the fuse switch to the “ON” position.
	Batteries are not fully charged	Charge batteries and test backup time. If the problem persists, contact the responsible customer service representative.
	Batteries are defective	Contact customer service
	Charging device is defective	Contact customer service
OVERLOAD LED illuminates	Overload at UPS output	Reduce load to the permissible value
No communication between UPS and PC	Wrong serial connection cable	Check whether the correct cable has been used (standard modem/null modem cables are not permissible)
	Interface on the PC is being used by another process or is defective.	Check whether other software/service is accessing the interface on the PC; try selecting a different serial interface.
	Interference on the data cable	Lay cables differently.

When the system works abnormally, the Fault LED will illuminate and the audible alarm will beep continuously. In this situation, the panel LEDs will indicate which part inside the UPS is out of order. The representations of fault conditions are listed as following:

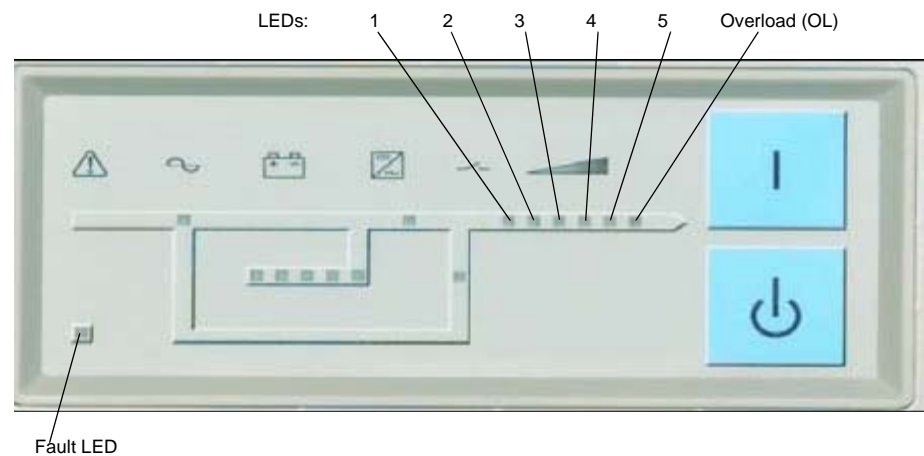

	Fault	LED	UPS Mode Before Fault	Condition	UPS Mode After Fault
1	BUS fault	Fault & 3	Line, Battery Test	Voltage > 450V Voltage > 400V +-BUS unbalanced over 40V Voltage < 230V	Bypass
			Battery	Voltage > 450V Voltage > 400V +-BUS unbalanced over 40V Voltage < 230V	No output
2	Inverter fault	Fault & 2	Bypass to line	Soft start fail	Bypass
			Line, Battery Test	Voltage > 276V Voltage < 140V	
			Battery	Voltage > 276V Voltage < 140V	No output
3	Overheating fault	Fault & 1	Bypass, Line, Battery Test	Temperature >90degree Celsius	Bypass
			Battery	Temperature >90degree Celsius	No output
4	Battery over voltage fault	Fault & 4	Bypass, Line, Battery Test	Voltage > 292V	Bypass
5	Battery overload	Fault & 5	Battery, Battery test	Load > 105%	No output
6	Inverter mode, output fault Short circuit fault	Fault, 1 & 2	Line, Battery test	Voltage < 50V & current > 20A	No output
			Battery	Voltage < 50V & current > 20A	no output
7	Battery fault / battery disconnect	Fault, 1 & 4 Battery chain LED flashing	Line, Bypass, Battery test	Voltage < 180V (H8) Voltage < 185V (DSP)	Bypass, Line
			Battery	Voltage < 180V (H8) Voltage < 185V (DSP)	No output
				Voltage > 200V (H8) Voltage > 192V (DSP)	
8	Charger fault	Fault, 1 & OL	Line, Bypass, Battery test	Charge on, but battery <240V	Bypass
9	RPO active	Fault, 2 & 4	Any mode	RPO hardware active	No output

Troubleshooting

	Fault	LED	UPS Mode Before Fault	Condition	UPS Mode After Fault
10	Parallel error	Fault, 3 & 4	Any mode	Parallel communication CAN bus loss	No output
11	Communications error	Fault, 2 & 4	Any mode	DSP with H8 communications error	Bypass or no output
12	Output failure	Fault, 1 & 5	Line, Battery	Output actual power \leq 800W	Bypass
13	Back feed active	Fault	Line, Battery	STS is break and cause a short circuit from inverter top bypass	Battery
14	Parallel fault	Fault, 3 & 4	Bypass, Line	Fault of units in parallel	Units effected no output

